

DNH7 series Fuse-Switch-Disconnecter



Model & Meaning

DN H 7 - □ / □ □ □
 ① ② ③ ④ ⑤ ⑥ ⑦

- ① Code of company
- ② Fuse-Switch-Disconnecter
- ③ Design code
- ④ Conerntional thermal cuurent
- ⑤ Poles
- ⑥ "0" means without auxiliary contacts;
"1" means with auxiliary contacts
- ⑦ "1" means denotes hang type;
"0" means denotes fixed type

Application scope

DNH7 series fuse type load isolating switch is applicable to high short circuit current circuit with AC 50(60)Hz, voltage up to 660V and rated working current up to 1600A. It possesses upper and lower end input and output structure. Lead in equipment with knife-edge and arc extinguishing equipment, and also can be operated with load. It is used as power switch, isolating switch and emergency switch, and for protecting current.

Principal technical parameter

Model	DNH7-160A			DNH7-250A			DNH7-400A			DNH7-630A		
Fuse size	00			1			2			3		
Rated operational voltage Ue V	400	500	690	400	500	690	400	500	690	400	500	690
Rated operational current Ie A	125	160	125	250	200		400	315		630	500	
Thermal current w/fuse link Ith A	160			250			400			630		
Rated insulation voltage Ui V	1000			1000			1000			1000		
Rated impulse withstand voltage Uimp V	8000			8000			8000			8000		
Fuse protected short circuit making kA ms	50			50			50			50		
Rated making and breaking capacity	AC23B	AC22B	AC21B	AC23B	AC22B	AC21B	AC23B	AC22B	AC21B	AC23B	AC22B	AC21B
Rated frequency Hz	50 / 60			50 / 60			50 / 60			50 / 60		
Power loss at Im without fuse-link/phase W	12W			23W			34W			48W		

DNH7 series Fuse-Switch-Disconnecter

Model	DNH7-160A	DNH7-250A	DNH7-400A	DNH7-630A
Electrical durability	200	200	200	200
Mechanical durability	1400	1400	800	800
Degree of protection	Open	IP20	IP20	IP20
	Closed	IP30	IP30	IP30

Overall & Installation Dimension

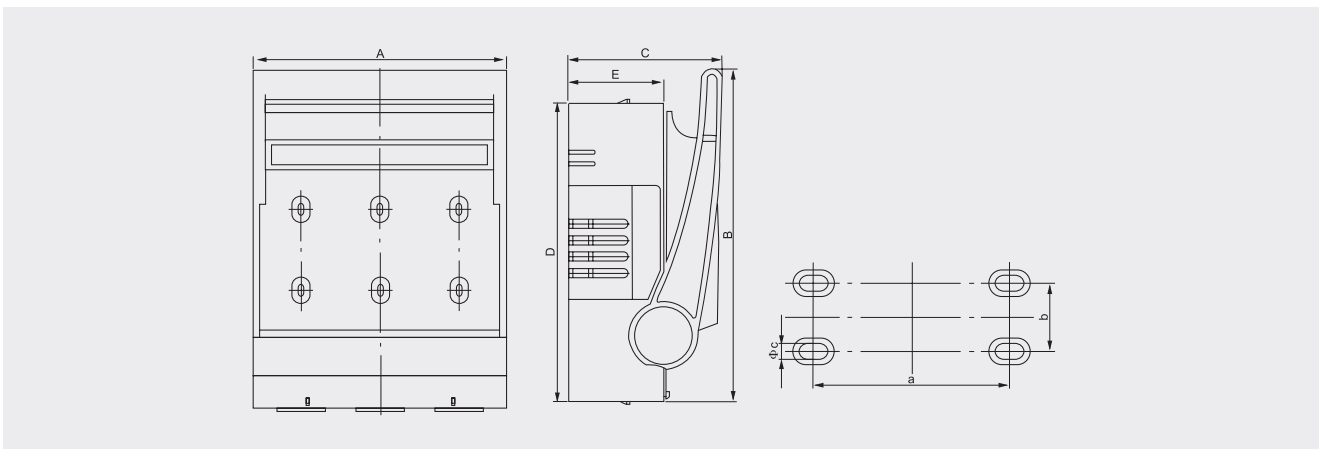

Model	Overall (mm)					Installation (mm)			Fuse
	A	B	C	D	E	a	b	Φc	
DNH7-160	105	184	88	160	43	73	25	Φ7	NT00
DNH7-250	184	268	116	230	66	115	50	Φ11	NT1
DNH7-400	210	285	129	256	81	140	50	Φ11	NT2
DNH7-630	250	328	138	315	86	150	50	Φ9	NT3